

15V Input Converter Generates -185V at 50mA

Additional Information: [Quick View Data Sheet for the MAX668](#)
[Quick View Data Sheet for the MAX4130](#)
[Samples and Literature Order Form](#)
Powerhelp@design.maxim.com

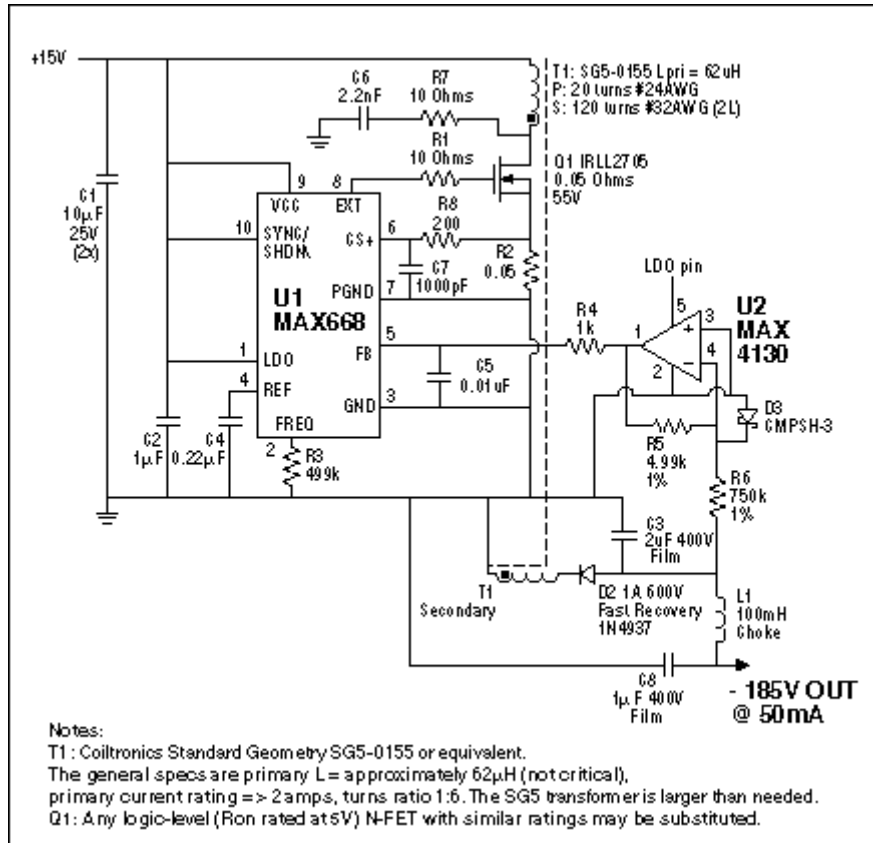

This circuit uses the MAX668 and a transformer (which will need about a one-to-six turns ratio) to make a flyback converter. The op amp inverts the feedback from the negative output voltage.

The circuit above generates -185V at 50mA from a +15V input. Based on a MAX668 transformer flyback application, the circuit employs a custom transformer to generate -185V through a combination of turns ratio and duty cycle. The transformer is designed on an SG5-size bobbin to facilitate the winding and to decrease the leakage inductance.

D2 is chosen as a fast-recovery diode to moderate the cost for a high-breakdown voltage part. Because the diode will see 185V + (6 x Vin) + flyback due to leakage inductance, a 600V rating is necessary. C3 is chosen as a film capacitor to get high voltage rating and high ripple-current capacity. A secondary LC (L1 and C8) reduces output ripple from 100mVp-p to less than 5mVp-p.

668-185w, November 2000

MORE INFORMATION

MAX4130: [QuickView](#) -- [Full \(PDF\) Data Sheet \(424k\)](#)

-- [Free Sample](#)

MAX668: [QuickView](#) -- [Full \(PDF\) Data Sheet \(304k\)](#)

-- [Free Sample](#)